

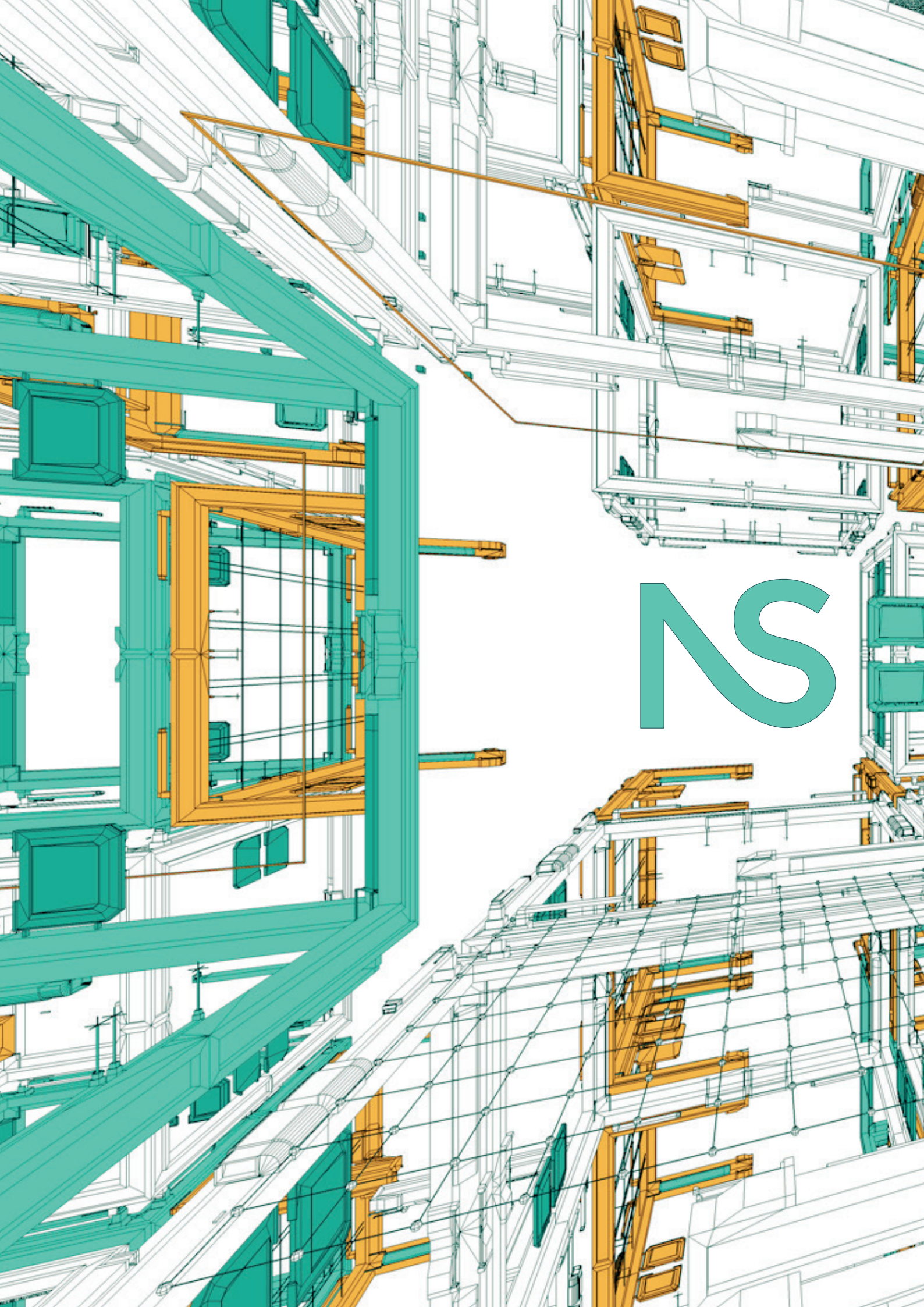

 **netservice**
Information Technology

Start your change



NS

THE RESPONSIVENESS OF A LEAN AND EFFICIENT STRUCTURE, THE SOLIDITY OF A GREAT OPERATOR

Efficiency, transparency, and simplicity are at the core of how we design and manage complex processes within organizations. We put culture at the centre of the digital world and imagine new meanings for the words Innovation and Technology.

We invest in research and training in order to remain at the forefront of innovation and transformative change, anticipate market demands, and respond promptly to a growing demand for reliable, secure IT systems.

PRODUCTS AND SOLUTIONS

ASTREA DIGITAL PLATFORM

INORDINE

GIUSTIZIA METROPOLITANA

ASTREA SOLIDO CMS

ETHERNA

B-SUPPLY

B-VOTING

B-CERT

SEEDOO

RESEARCH AND DEVELOPMENT

METAGIUSTIZIA

CRYPTO-VOTING

HINT

CAFCHA

AIND

CASCO

ALMACERT

DEMETRA

ABCDE

NET JUSTICE

TECHNOLOGIES

CRM

DEVOPS

IDENTITY MANAGEMENT

BLOCKCHAIN

ARTIFICIAL INTELLIGENCE

ENTERPRISE CONTENT MANAGEMENT

DATA MANAGEMENT

COMMUNICATION PLATFORM

TESTING

DATABASE

OS

BUSINESS LOGIC

FRONTEND

SERVICES AND CONSULTANCY

E-JUSTICE

CYBER-RISK AND GDPR

SYSTEM INTEGRATION

APPLICATION MANAGEMENT

TRAINING

OUR HISTORY SPEAKS FOR ITSELF

We started off as an independent company and subsequently joined a large group from which, over the course of a decade, we developed the expertise to deliver large projects, taking full advantage of our agile and efficient structure. **We offer reliable, secure IT solutions with prompt support and assistance.**

In twenty years we have transformed into an established limited company, registered as an Innovative SME, capable of competing in both national and international markets.

1997 | THE ORIGINS

Net Service was established in **Bologna** and immediately stood out for the creation of information systems dedicated to managing complex organizations

2004 | THE FIRST STEPS

Net Service became part of the **Datamat Group**, Group specialized in designing and developing high profile ICT solutions for the Public Administration

2006 | JOINING FINMECCANICA

Net Service joins the **Finmeccanica Group** distinguished itself as a center of excellence for the design and development of ICT systems for judicial processes.

2014 | NET SERVICE S.P.A. IS LAUNCHED

Net Service left the Finmeccanica Group and became a **Limited Company**

2015 | NEW OFFICES

Net Service added office in **Rome** and **Salerno** to its Bologna headquarters

2016 | INTERNATIONAL BREAKTHROUGH

Net Service officially placed itself on the international market with the launch of **Net Service Information Technology Ltd** in London

2018 | NET SERVICE GROUP IS ON THE RISE

Net Service acquired **FlosLab**, the spin-off of the University of Cagliari focusing on blockchain and smart contracts. **Net Service Digital Hub** was opened to the public and it quickly became one of the leading digital transformation hubs in Northern Italy. As the group expanded Net Service opened new Italian offices in the cities of **Lecce**, **Cagliari** and **Rende**.

2019 | NET SERVICE LUX IS FOUNDED

Net Service adds another arm to its internationalization process with **Net Service Lux** headquartered in **Luxembourg**

2020 | INTERNATIONAL CONSOLIDATION

Net Service leads the groups of undertakings that will empower the information technology of the **European Court of Justice**

2022 | THE EXPANSION OF NET SERVICE GROUP

Net Service acquires the companies **RealValue Consulting**, **Realvalue Academy** and **GT50** increasing competitiveness on technologies enabling the digital transformation processes.

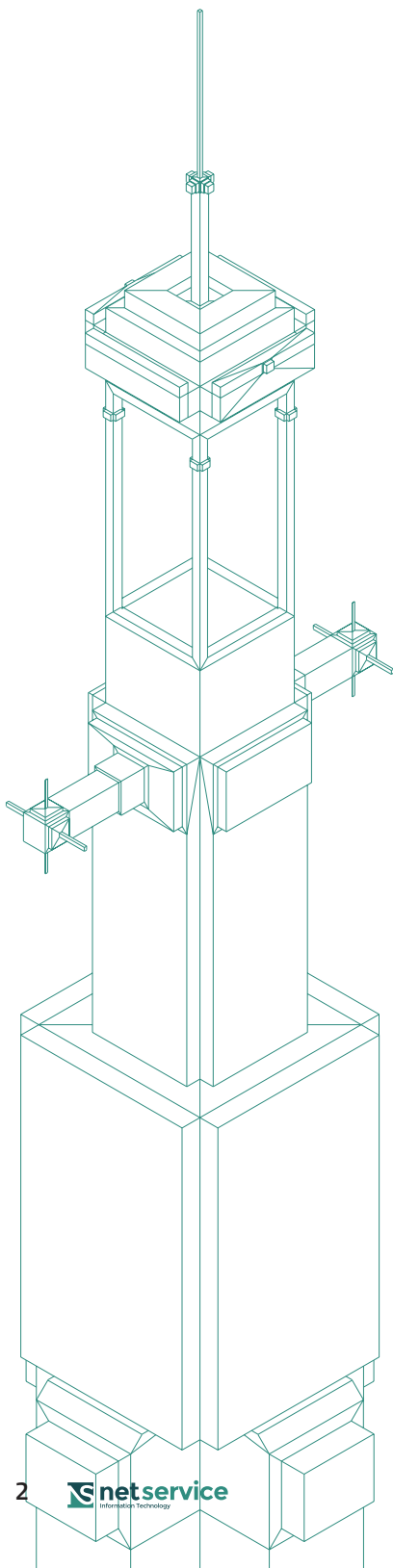

OUR VALUES: WHAT DEFINES US

We are among the first companies in the IT sector in Italy to have obtained for its integrated management system the underlying international certifications under ACCREDIA accreditation.

What signals our experience in the sector and distinguishes our technological and business competence are the numerous certifications awarded to us over time. In 2016 we were also included by the AGCM in the list of companies with **Legality Rating**.



ISO 9001
QUALITY



ISO 14001
ENVIRONMENT



ISO 45001
WORKPLACE SAFETY



ISO 27001
INFORMATION SECURITY
extended to ISO 27017 and ISO 27018



ISO 20000
SERVICE
MANAGEMENT
SYSTEM



SA 8000
SOCIAL
ACCOUNTABILITY

AN ETHICAL AND COLLABORATIVE APPROACH

The guidelines on **Quality, Transparency, Legality, Environment, Health and Safety of Workers and Information** are engraved in our **Company Policy**.

We believe in honesty, respect for regulations and protection of the environment. We believe that **meritocratic growth and collaboration within working groups** are fundamental in providing cutting-edge solutions. As a result, in 2012 we adopted an organization, management and control model of our activities inline with Legislative Decree no. 231/2001 requirements and, in compliance with the provisions established by law, we adopted a **Code of Ethics**.

MAINTAINING GOOD CUSTOMER RELATIONS

We work towards the principles of trust and collaboration in order to meet our customers' demands and start an actual process of dematerialization of document flows and the digitalization of their administrative, commercial or business activities.

We combine an incremental development process (i.e. Agile) with a classic waterfall process that is capable of providing customers with tailor-made, non-invasive solutions that are perfectly integrated to their environment.

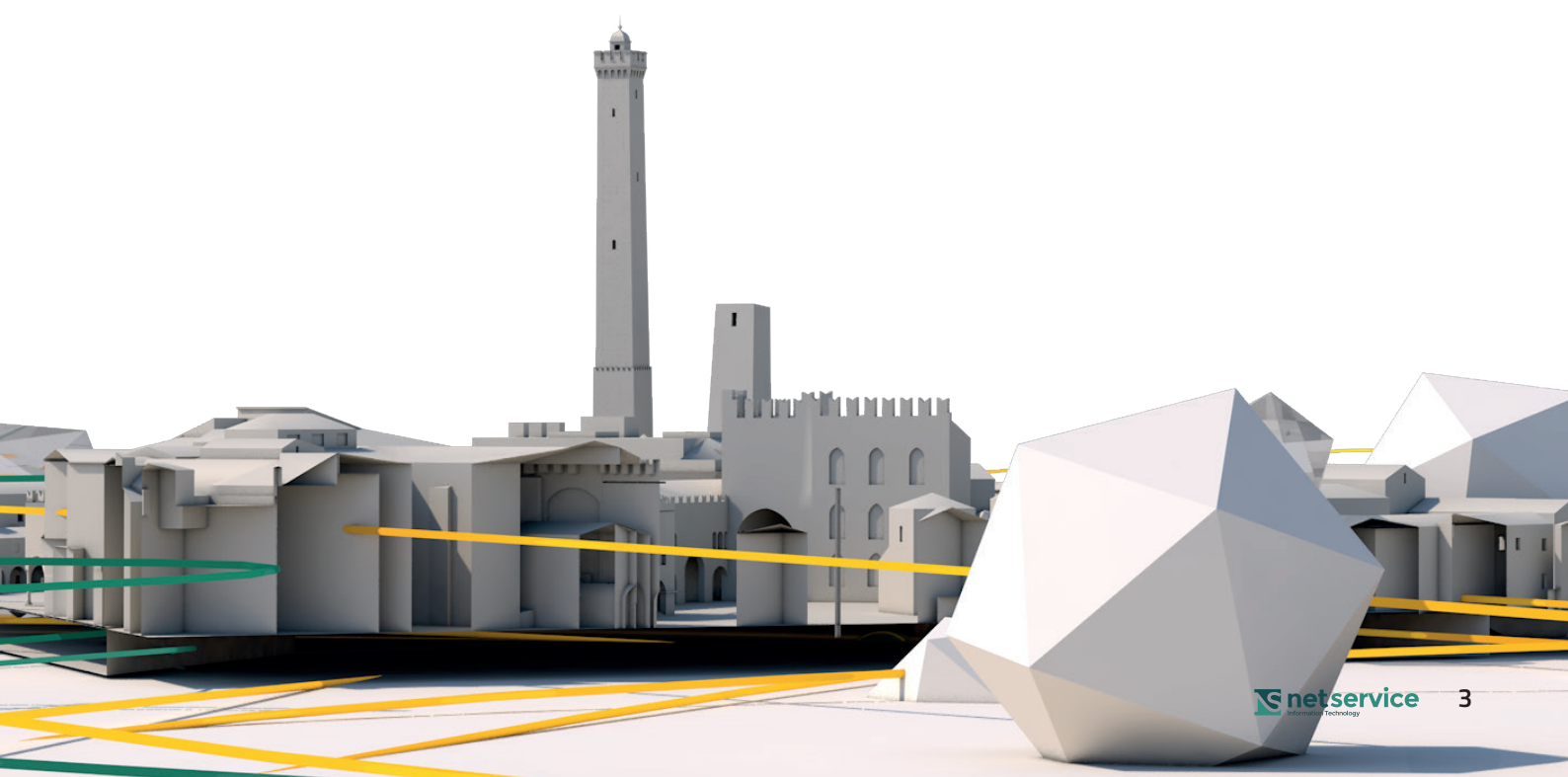

A YOUNG AND QUALIFIED ENVIRONMENT

The security and professional growth of our employees and partners is fundamental. We invest in their training, enhancing both personal and professional skills and attitudes.

190+

is the number of our employees. All with the utmost IT skills



Project Managers are **PMP** certified

36 y.o.

the average age of our employees and collaborators does not exceed 36 y.o.



Service Managers are **ITIL v4** certified

72%

of our employees know more than one programming language



ICT designers are **RHCE** - Red Hat Certified Engineer certified

42%

of our employees have already achieved a certification



Development Team Leaders are **Oracle Certified Professional Java SE 8** and **AgilePM/Scrum Master**



SOLIDITY AND EXPERIENCE

We have twenty years of experience in the field of Information, Communication and Cyber Security Technologies



ETHICAL AND COLLABORATIVE APPROACH

We believe in honesty and environmental protection. Our projects are the result of shared research, commitment and ambition



EMPLOYEE CARE

We are convinced that the safety and professional growth of our team are fundamental in order to offer cutting-edge solutions



COMPETENCE AND RESPONSIBILITY

The training and well-being of our employees are the basis of our professional work as well as the care and satisfaction of our customers

AN INTEGRATED ECOSYSTEM OF PRODUCTS AND SOLUTIONS FOR A TRUE DIGITAL TRANSFORMATION PROCESS

Net Service develops innovative, effective and safe products and technological solutions for Central and Local Public Administrations, Medium and Large Enterprises, Professional Bodies and Professionals.

The approach is *user driven*, or rather it provides technology to support processes and not vice versa. This means analysing, in advance, the technological and organizational environment, identifying the best solutions with customers and facilitating the digital transformation which best suits their needs.

» ASTREA DIGITAL PLATFORM

INORDINE

GIUSTIZIA METROPOLITANA

ASTREA SOLIDO CMS

» ETHERNA

B-SUPPLY

B-VOTING

B-CERT

» SEEDOC

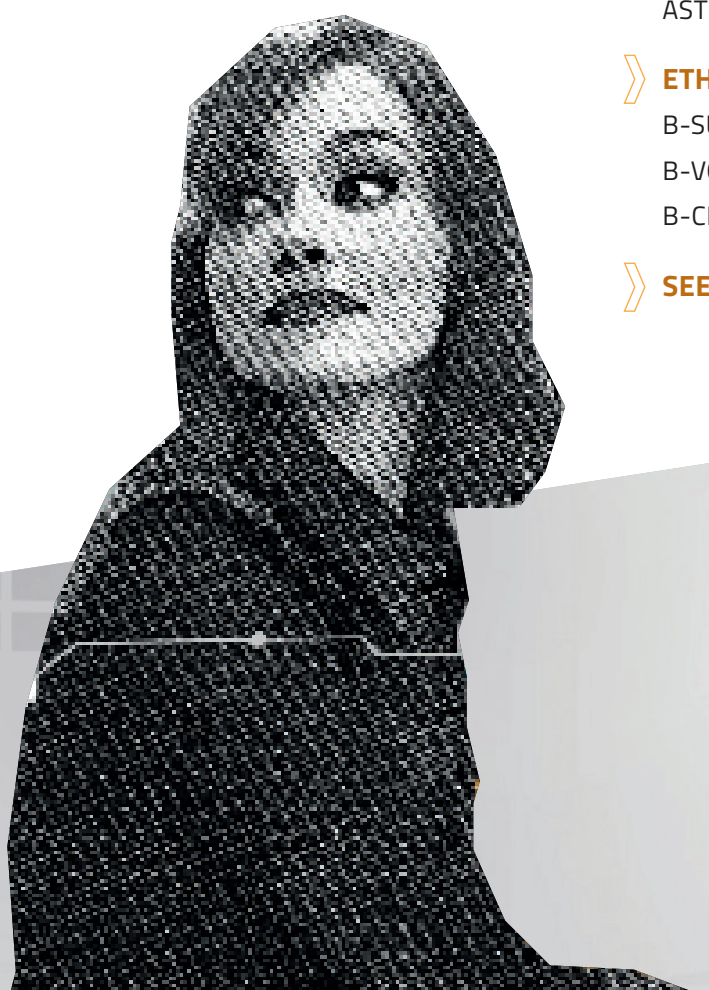

THE TECHNOLOGICAL FACE OF INNOVATION



Astrea® Digital Platform is the integrated technological platform for managing and monitoring business activities developed by Net Service. The solution ensures direct, structured access to heterogeneous data sources, both internal and external, to corporate information systems.

The platform can be verticalized for Medium and Large Enterprises, Local and Central Authorities and Public Administrations.

ASTREA DIGITAL PLATFORM SOLUTIONS



Much more than just simple Management System

INORDINE is the technological solution developed by Net Service aimed at **simplifying and organizing the workflows of Professional Bodies and Associations.**

The application is modular and full-web, complete with **management software**, an **Institutional Portal** and a series of **additional modules** that help support the administrative offices of Bodies and Associations in carrying out their work.



The Case Management System for Enterprise-class Organizations

Astrea® Solido CMS (Case Management System) is an intuitive, efficient and easy-to-configure web application, which allows Courts, Companies and Central and Local Administrations to effectively manage their procedures and official documentation.

The sophisticated information system was adopted in 2015 by the Unified Patent Court, the Court for unitary patent protection in Europe, and by ANAS, the national road authority.



Digital Transformation for the Public Administration

Giustizia Metropolitana® is the innovative technological solution developed by Net Service S.p.A. for the digitalization of processes and electronic interchange between Local Authorities, citizens and the Central Public Administration.

The technological heart of the platform lies in the Astrea Digital Platform, which is capable of offering Public Administrations and Companies digital systems and tools perfectly tailored to their specific needs.

Awards and accolades:



SMAU 2016 and 2019
Innovation Awards



2016 Reconnaissance Manual
of the Superior Council of the
Judiciary



Award in the field of Justice,
transparency, participation of
the PA Forum 2018 and 2019



Smart Working Award
and Collaboration
Digital360 Awards 2018

BLOCKCHAIN-AS-A-SERVICE FOR HIGH-LEVEL SERVICES



Etherna is an interoperability platform that allows multiple subjects to use multiple blockchain technologies thanks to its interface with the ETHERNA Sidechain and the public Blockchains of Bitcoin, Ethereum and Litecoin.

A platform that makes the use of technology simple and transparent for any application and process integration.

ETHERNA SOLUTIONS



For certifying and tracking production processes

B-Supply is a certification and tracking framework for production processes based on Blockchain. It represents valid support for quality control within its production chain and limits the risk of counterfeiting, in order to protect the authenticity of the product. The system records, in a permanent, immutable and punctual manner, all the progresses of the production process phase with the help of Smart Contracts.

The certification guarantee on Blockchain offers its customers maximum transparency and allows the reconstruction of the entire history of a product right back to its origins.



The innovative integrated electronic voting system

B-Voting (Blockchain-Voting) is the innovative electronic voting system developed by Net Service, integrated with one or more electoral event management procedures: system set-up, distribution of credentials, voting, collection of ballot papers, counting of preferences, publication of results.

The objective of this solution is to overcome the current limits of the so-called e-voting systems, releasing the voting organizer from the responsibility of guaranteeing anonymity and non-alterability of the vote and transferring these guarantees to the platform itself.



The certification service on Blockchain

B-Cert is a portal that allows an organization to certify any type of document or message on public Blockchain (es. Bitcoin, Ethereum, Litecoin), by obtaining a unique digital successful registration certificate.

B-Cert acts as notarisatation systems useful for guaranteeing the existence of specific digital content on a given date, and for proving ownership of content before anyone else.



For improved document and protocol management

Seedoc is an Open-source platform for computer protocol recording and document management that enables **complete management of the document and protocol process**, reducing the time and costs of process archiving and management.

Innovation is a value of primary importance.

Research and development is essential in Net Service's corporate culture, especially concerning competence and safety.

All research and development activities are carried out within a dedicated area with highly qualified personnel tasked with identifying opportunities for innovation. The resulting innovative technologies and solutions developed are thus transferred to the production and marketing divisions of the company.

This area is well-established and has been carrying out innovative projects for many years either as the result of a decisive group investment or in collaboration with the academic and research world, also through funded research projects.

Today, the Net Service Research and Development Centre is engaged in new research areas, such as the study of new **Process Mining** and **Machine Learning** technologies, as well as continuing its research in the field of development of systems based on **Blockchain and Artificial intelligence**. These systems are technologically advanced and designed to solve complex problems connected delete to the **Big Data** and **Cyber Security** sectors and, more generally, to secure data management in distributed environments.



ABCDE
The innovative DAPP development process



AIND
An advanced framework for Businesses and PA



HINT
The Cloud platform for Telemedicine



METAGIUSTIZIA
Artificial Intelligence at the service of Justice



CRYPTO-VOTING
The e-voting system based on Blockchain technology

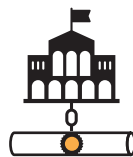

ALMACERT
To authenticate university degree certificates via Blockchain



CAFCHA
The Blockchain serving the agri-food supply chain



DEMETRA
More safety and quality for the agri-food industry



CASCO
The dynamic ICO evaluation platform



NET JUSTICE
Technology for e-Gov and e-Justice across Europe

TECHNOLOGIES TO INTEGRATE AND MANAGE DIGITAL TRANSFORMATION



Enablers of new business models and opportunities

Net Service accompanies Public Bodies and Private Organizations in the redefinition of strategies, products and services, in line with the evolution of digital technologies and consumer behaviour.

This translates into looking at technologies not only as tools at the service of innovation, but above all as enablers of new business models and new opportunities.

With twenty years of experience in the development of Open Source software and IT systems for structured organizations and large public bodies, Net Service aims to bring Public Administration and IT departments of Companies up to date.

To do this Net Service provides collaborative cloud-based technologies, cutting-edge Cyber Security solutions and additional innovative digital tools capable of redesigning approaches to developing internal systems; thus making them more agile and interactive and enhancing performance.

The objective is to facilitate the Digital Transformation process of Companies and Public Bodies, allowing them to start a tangible process of dematerialization of document flows and the digitalization of administrative, commercial and business activities.

OUR TECHNOLOGICAL ECOSYSTEM

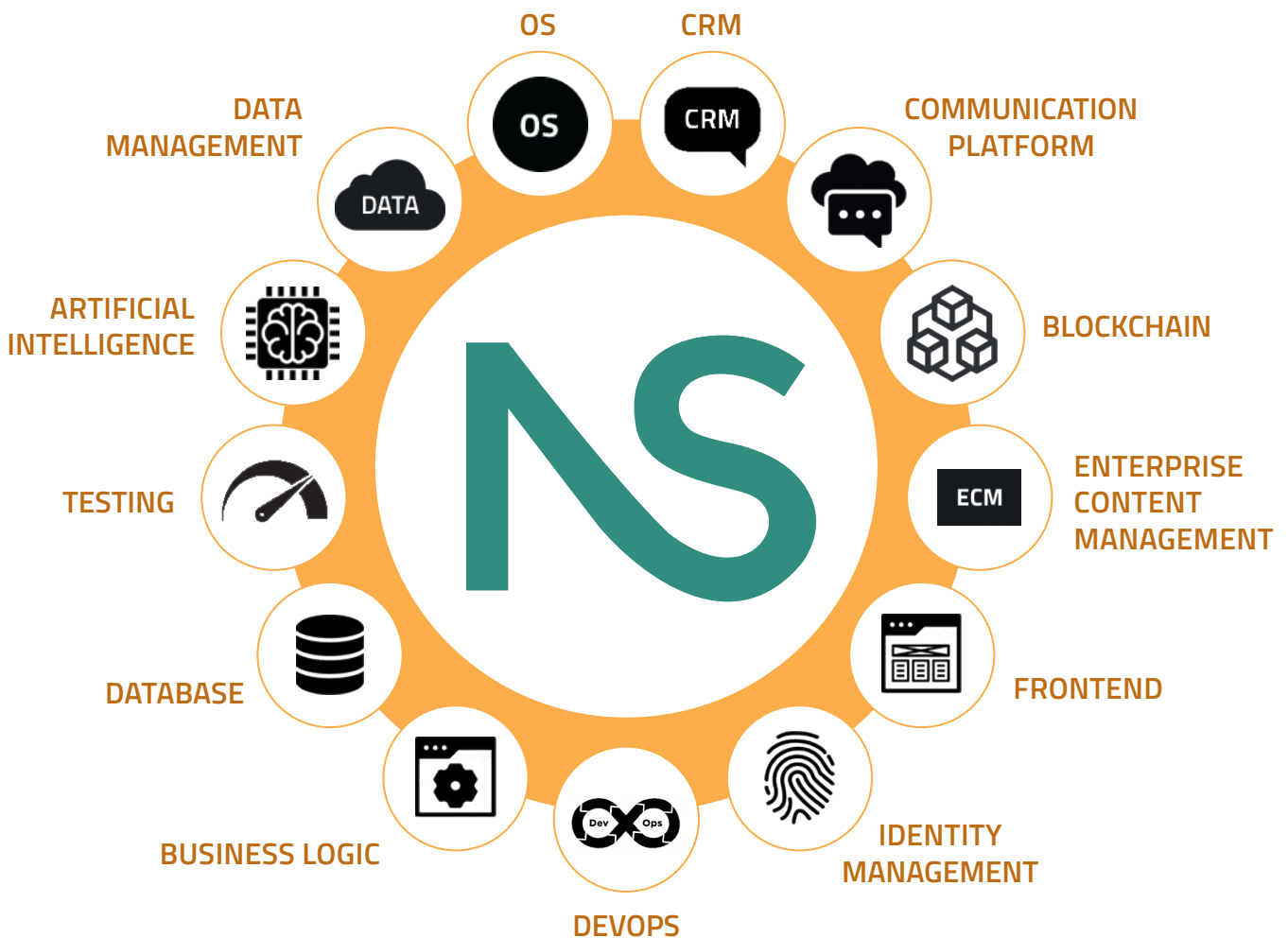

SERVICES AND CONSULTANCY

A robust support to get the most out of technology

Net Service does not limit itself to offering a simple technological consultancy service, but additionally supports its customers from the first analysis of an organization, to ensure that all applied technology is effective and modeled on the specific needs of the client.

TARGETED INTERVENTIONS...

Net Service has a team specialized in various areas of application maintenance (**Application Management**) with a specific department responsible for guaranteeing **effective and continuous assistance** to the client backed up by a rapid response protocol to resolve any problem.

BLOCKCHAIN CONSULTING: THE JEWEL IN OUR CROWN

Net Service was one of the first companies in Italy to invest in research for Blockchain (since 2014). Highly competent in consulting and the industrialization of platforms and software, **Net Service has a cutting-edge Competence Center in Cagliari**, through its subsidiary FlossLab (the first spin-off of the University of Cagliari), **specialized in Blockchain and Open Source technologies.**

The success of an information system is closely related to the optimization the intervention of business processes has brought and it is from this assumption that the Company begins.

... AND TAILOR-MADE SERVICES

The company supports clients in securing the management of information (**Cyber Risk Management**) beginning from a first field verification approach. Thanks to its **specialists and Certified Lead Auditors 27001 and 27017 | 27018**, Net Service offers consultancy and training services for companies looking to seriously address **Cyber Security and GDPR compliance** issues. The company also offers a **Hosting service in secure and certified Data Center environments.**

THE SERVICES OFFERED BY OUR TEAM OF QUALIFIED EXPERTS IN THIS SPECIALIST AREA ARE:

- Support for integration of existing Legacy systems
- Development of document-management systems supporting the production process
- Development of applications for clients and end-users
- Consulting and support the use of Blockchain within the production context
- Integration with existing management software processes and IOT devices for automatic Blockchain certification



In 2018 Net Service became an active member of INFRACHAIN, a European non-profit organization supported by the government of Luxembourg,

created to establish governance principles in the Blockchain sector and guided by the community itself in its operations.

SERVICES AND CONSULTANCY

Customized interventions, consultancy and support activities



E-JUSTICE

Know-how and cutting-edge technology at the service of the Justice's information systems



National and international Competence Center dedicated to the justice sector, security and the digital transformation of Public Administration, with strong process expertise and robust digital solutions designed to improve efficiency and reduce costs in e-Justice digitalization projects.



CYBER RISK MANAGEMENT E GDPR

Information and sensitive data more secure and protected



State-of-the-art, **tailor-made solutions for the secure management of sensitive information and data**. Specialized consultancy for enacting a **GDPR compliance process** ideal for companies and organizations tasked with managing the changes necessary to comply with new European privacy regulations.



SYSTEM INTEGRATION

Dialogue between different systems and a functional, efficient IT structure



System integrator for medium and large enterprises capable of integrating and enabling communication between different systems. Net Service delivers IT structure projects capable of exploiting the potential of the equipment available, optimizing its functionality while guaranteeing the maximum security of its data.



APPLICATION MANAGEMENT

Developments under control



Corrective, adaptive, and evolutionary maintenance interventions necessary for capable monitoring of IT systems and applications, including **first and second level Change Management and Assistance Support services for Organizations and Central and Local Authorities**.



TRAINING

Advanced skills to make an impact



Continuous training of employees and customers to enhance skills. Net Service Digital Hub is an innovative Business and Competence Center available to companies and professionals looking to overcome the challenges of Digital Transformation and learn the required digital skills.

THE NET SERVICE GROUP



BOLOGNA - via Montegrappa, 4/d
CAGLIARI - via Cesare Battisti, 14
LECCE - via Colonnello Costadura, 2\c
RENDE - via Pedro Alvares Cabral, 14
SALERNO - via Roma, 7



CONTACTS

www.netservice.eu
info@netservice.eu
+39 051 6241989



LONDON
7/10 Chandos Street



CONTACTS

www.netservice.eu
info@netservice.eu



LUXEMBOURG
65, Boulevard de la Petrusse



CONTACTS

www.netservice.eu
info@netservice.lu



CAGLIARI
Via Cesare Battisti, 14



CONTACTS

www.flosslab.com
info@flosslab.com



ROME
Viale degli Ammiragli, 67



CONTACTS

www.gt50.org
info@gt50.org





REAL **ALUE** CONSULTING

MILAN - Via Gadames, 57/7
VILLAFRANCA DI VERONA - Via Spagna, 24
LUGANO - Via Besso, 19
WARSAW - Plac Powstanców



CONTACTS

www.realvalueconsulting.eu
info@realvalueconsulting.eu

REAL **ALUE** ACADEMY

RENDE
Via Pedro Alvares Cabral, 6



CONTACTS

www.realvalueconsulting.eu
info@realvalueconsulting.eu



BOLOGNA
via Montegrappa, 4/d



CONTACTS

www.netservice-digitalhub.com
info@netservice-digitalhub.com

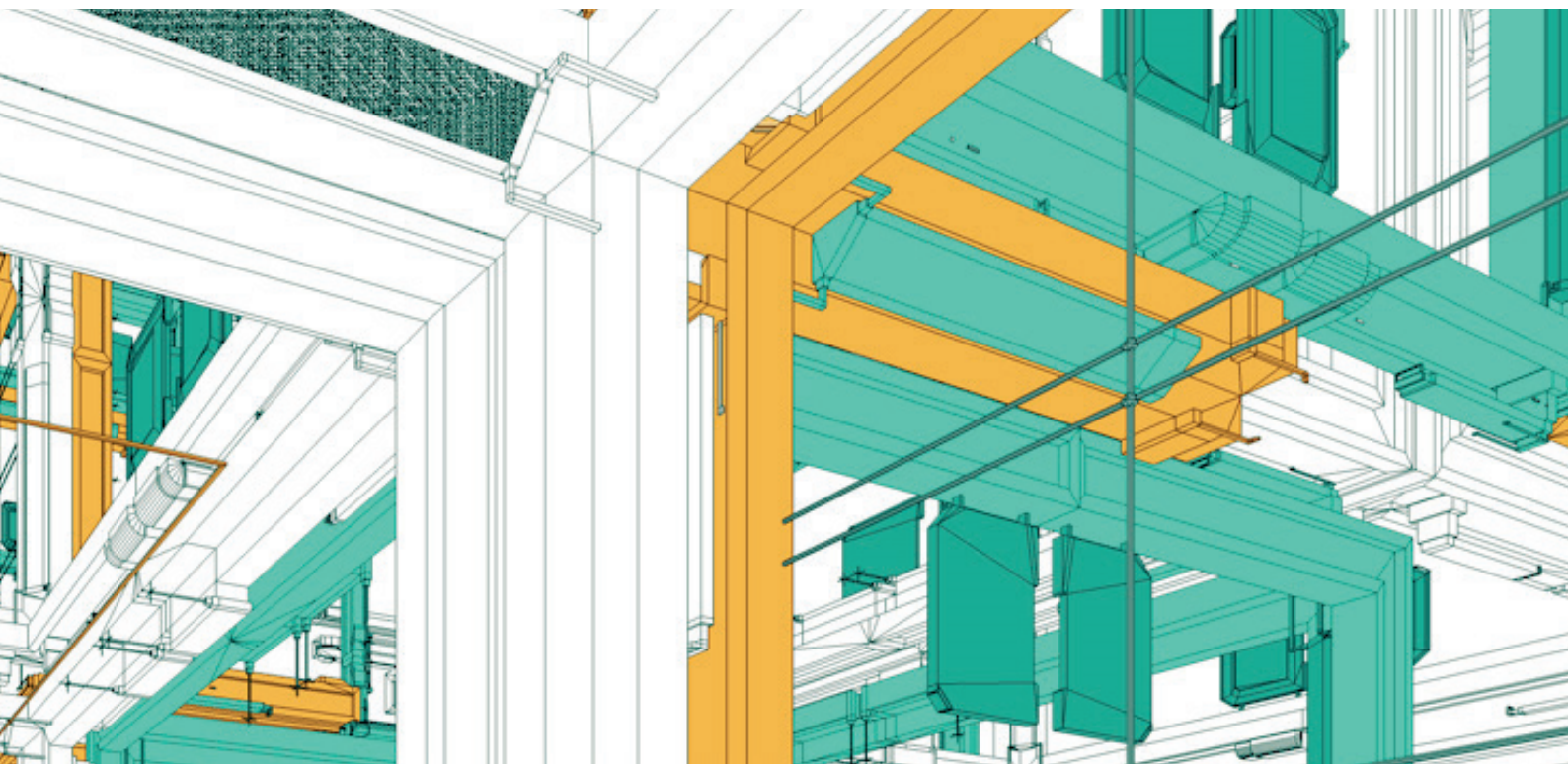

Rev. 01 of 17/03/2023



www.netservice.eu